

4 – WAY MULTI DIRECTIONAL SO 40 S TRUCK

- ❑ Powerful PERKINS Diesel Engine
- ❑ Hydrostatic Bosch-Rexroth Transmission
- ❑ 4 Way Multi Directional steerable wheels moves in all directions
- ❑ Driver comfort cab with excellent all round visibility
- ❑ Robust simple to use and maintain

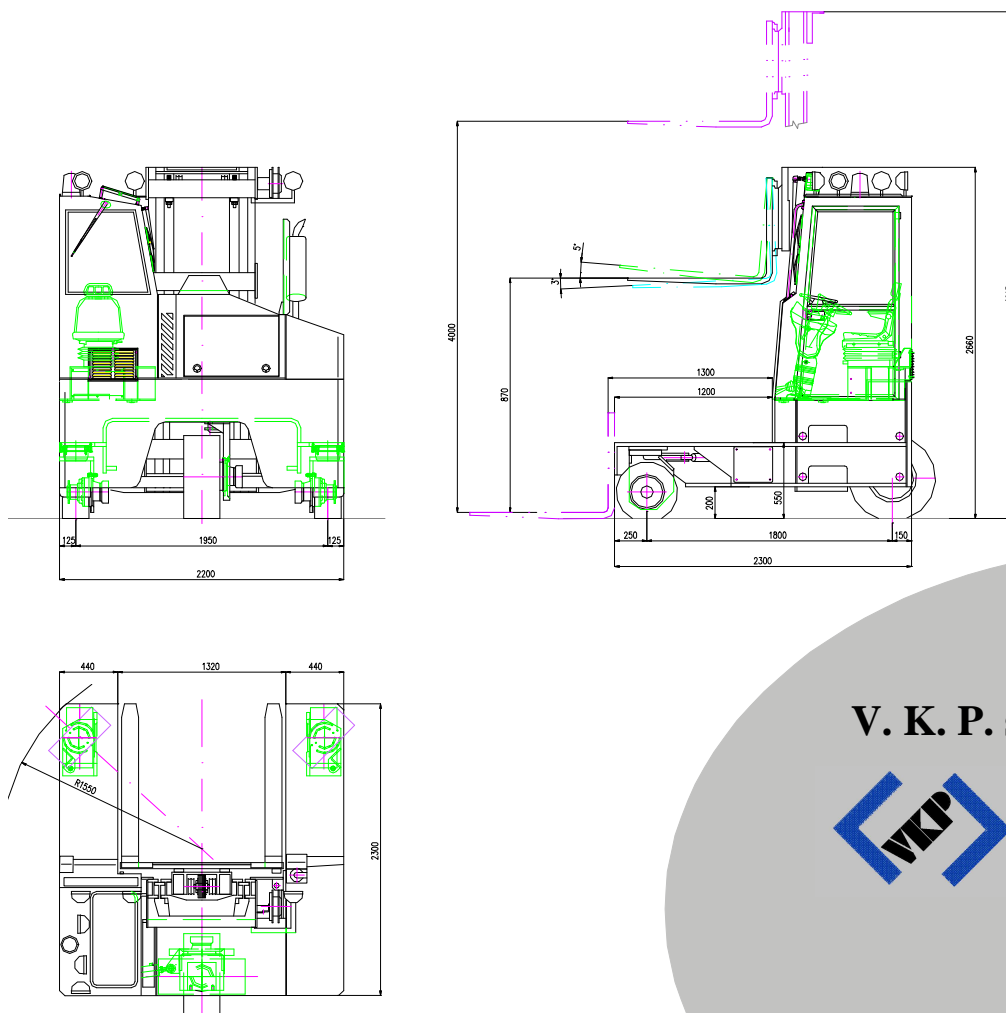

V. K. P. spol. s r.o. Chrudim
Čáslavská 523,
537 01 Chrudim
Czech Republic
tel.: +420 469 671 773
fax.: + 420 469 670 105
e-mail : vkp@vkp.cz
www.vkp.cz

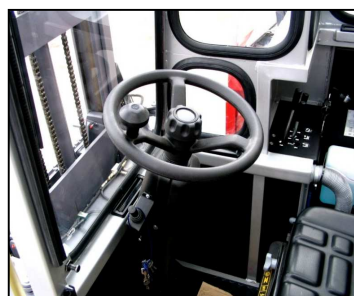

Marking	1	Manufacturer		VKP	VKP	VKP	
	2	Model	SO 40S	SO 40S-40-6	SO 40S-40-7	SO 40S-40-8	
	3	Capacity	Q	kg	4000	4000	4000
	4	Loadcentre	c distance	mm	600	700	800
	5	Driving	electric (Battery), Diesel, Petrol, LPG		Diesel	Diesel	Diesel
	6	Steering	Hand, Walk, Stand, Seat		seat	seat	seat
	7	Tyres	V = Cushion/Rubber, L =Pneumatic		V/L	V/L	V/L
	8	Wheel	Number front/rear		2/1	2/1	2/1
Dimensions	9	Lift	h3	mm	4000	4000	4000
	10	Free lift	h2		870	870	870
	11	Fork dim.	height x width x length	mm	45/130/1200	50/130/1400	50/140/1600
	12	Tilting	of mast front/ rear	1°	3/5	3/5	3/5
	13	Dimensions	L - Length	mm	2300	2500	2700
	14		B - Width	mm	2200	2200	2200
	15		h1 closed height *)	mm	2915	2915	2915
	16		h4 extended height *)	mm	4915	4915	4915
	17		H1 Cabin height *)	mm	2660	2660	2660
	18		V reach out	mm	1300	1500	1700
	19		B1 chassis cut out	mm	1320	1320	1320
	20		B2 Fork adjustment min - max	mm	260-1260	260-1260	260-1260
	21		H platform height*) /H2 engine hood height	mm	550	550	550
	22		NB platform width	mm	1200	1400	1600
	23	Turning radius	Wa outer/ Wi inner	mm	2400/0	2600/0	2800/0
24	Aisle dim.	Ast4 for straight ahead	mm	2400	2400	2400	
25		Aw1/Aw2 for turning 90°	mm	2500	2700	2900	
Capacity	26	Stability	Acc. FEM/ DIN - EN		yes	yes	yes
	27	Speed	Travel with/ without load	km/h	15/16	15/16	15/16
	28		Lift with/ without load	m/s	0,3/0,36	0,3/0,36	0,3/0,36
	29		Lowering with/ without load	m/s	0,5/0,3	0,5/0,3	0,5/0,3
	30		Reach out of mast	m/s	0,25	0,25	0,25
	31	Drawbar pull	Hook	daN	2200	2200	2200
32	Gradient	with/ without load	%	20/37	20/37	20/37	
Weight	33	Weight	incl battery	kg	6000	6200	6400
	34	Axle load	with/ without load	kg	5250/4750	5250/4950	5250/5150
Travel	35	Tyres	No. of tyres front/ rear		2/1	2/1	2/1
	36		Dimensions front		200/50-10	200/50-10	200/50-10
	37		Dimensions rear		27x10-12/16PR	27x10-12/16PR	27x10-12/16PR
	38	Axle distance	Y	mm	1900	2100	2300
	39	Track	Cl Tyres front/ rear	mm	2000/0	2000/0	2000/0
	40	Clearance	m1 center mast, loaded *)	mm	200	200	200
	41		m2 center truck, loaded *)	mm	200	200	200
42	Brakes	foot / hand		foot / hand	foot / hand	foot / hand	
43		wet / mechanic		hydraulic	hydraulic	hydraulic	
Drive	44	Battery	type		starter	starter	starter
	45		voltage/ Ah	V/Ah	12/100	12/100	12/100
	46		Weight	kg	25	25	25
	47	Engine	Manufacturer / type		Perkins 404C-22	Perkins 404C-22	Perkins 404C-22
	48		Performance ISO / TR 14 396	kW	38	38	38
	49		RPM	n/min	3000	3000	3000
	50		Torque	Nm/n	143/1800	143/1800	143/1800
	51		no ot/ cylinders/ volume		4/4/2200	4/4/2200	4/4/2200
	52	Clutch	Type				
	53	Shifting	Type		stepless	stepless	stepless
54	No of gears, front/ rear			1/1	1/1	1/1	
55	Transmission	Type		hydrostatic	hydrostatic	hydrostatic	
Coplments	56	Hydr. pressure	for attachments	bar	180	180	180
	57	Steering system	Type		hydrostatic	hydrostatic	hydrostatic
	58	Lighting	Yes / No		Yes	Yes	Yes
	*) without load, modification reserved without notice h1 = h3/2 + 915; h4 = h3 + 915						