

Sideloader

SB 80 Q

Technical data

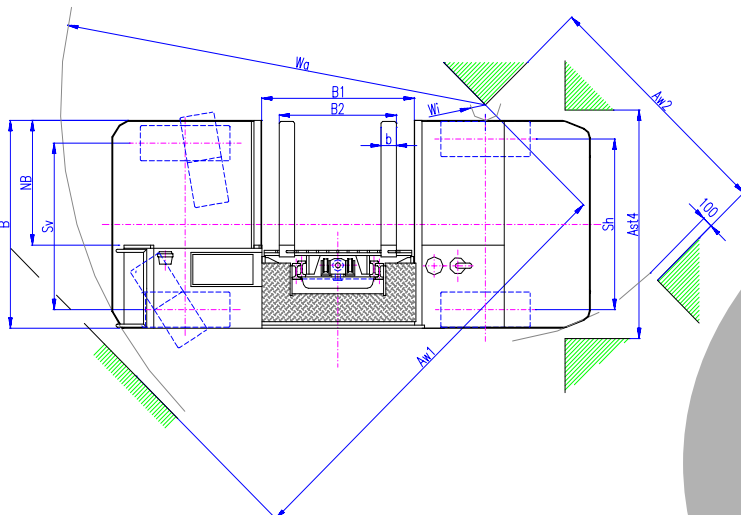
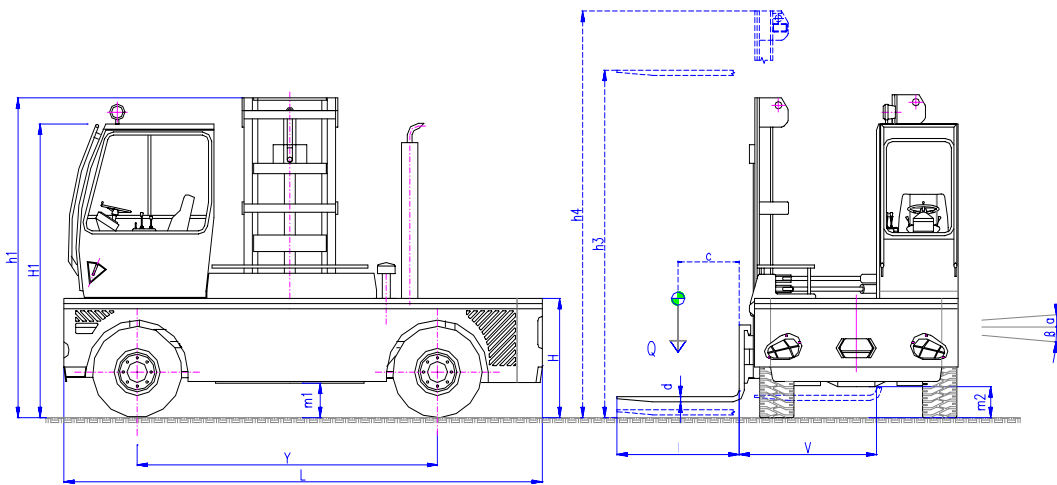

V.K.P. spol. s r. o. Chrudim

Na Valech 176, 537 01

Czech Republic

tel.: +420 469 610 852

fax: +420 469 610 851

e-mail: vkp@traveller.cz

www.vkp.cz



Marking	1	Manufacturer		VKP	VKP	
	2	Model	SB 80 Q	SB 80Q-40-6	SB 80Q-40-7	
	3	Capacity	Q	kg	8000	8000
	4	Reach centre	c distance	mm	600	700
	5	Type of engine	Electric, (battery), Diesel, LPG		Diesel	Diesel
	6	Steering			seated	seated
	7	Tyres	V= Cushion/Rubber, L = Pneumatic		L/L	L/L
	8	Wheels	Number front/rear		2/2+	2/2+
Dimensions	9	Lift (standard)	h3	mm	4000	4000
	10	Free lift	h2	mm	1200	1200
	11	Fork dim.	height x width x length	mm	60/150/1200	65/150/1400
	12	Tilting	of mast front/ rear	1°	4/5	3,5/4,5
	13	Dimensions	L - Length	mm	4725	4725
	14		B - Width	mm	2000	2200
	15		h1 closed height *)	mm	3125	3125
	16		h4 extended height *)	mm	5125	5125
	17		H1 Cabin height *)	mm	2815	2815
	18		V reach out	mm	1300	1500
	19		B1 chassis cut out	mm	1500	1500
	20		B2 Fork adjustment min-max	mm	417-1400	417-1400
	21		H Platform height *)	mm	1150	1150
	22		NB platform width	mm	1200	1400
	23	Turning radius	Wa outer/ Wi inner	mm	4600/800	4650/750
24	Aisle width	Ast4 drive through	mm	2200	2400	
25		Aw 1/Aw2 for 90° – turning	mm	4600/2900	4700/3000	
Capacity	26	Stability	Acc.to FEM/DIN -EN yes/no		Yes	Yes
	27	Speed	Travel with/ without load	km/h	20/25	20/25
	28		Lift with/ without load	m/s	0,25/0,32	0,25/0,32
	29		Lowering with/ without load	m/s	0,4/0,25	0,4/0,25
	30		Mast extension	m/s	0,25	0,25
	31	Traction force	Hook	daN	5100	5100
32	Gradeability	with/ without load	%	20/47	20/47	
Weight	33	Weight of truck	incl.D37 battery	kg	11390	11690
	34	Axle load	with load front/rear	kg	8940/10450	9060/10630
Travel	35	Tyres	No. front/ rear		2/2	2/2
	36		Dimensions front		32x12. 1-15/24PR	32x12. 1-15/24PR
	37		Dimensions rear		32x12. 1-15/24PR	32x12. 1-15/24PR
	38	Axle base	Y	mm	2950	2950
	39	Wheel	CL Tyres front/rear	mm	1640/1680	1740/1880
	40	Clearance	m1 under lifting device *)	mm	260	260
	41		m2 centre of axle base *)	mm	260	260
	42	Brakes	foot/ hand		foot/ hand	foot/ hand
43	wet/ mechanic			hydr./hy.neg.	hydr./hy.neg.	
Drive	44	Battery	Type		starting bat	starting bat
	45		Voltage/ Ah	V/Ah	12/100	12/100
	46		Weight	kg	25	25
	47	Combust.engine	Manufacturer/ type		PERKINS 1104C-44	PERKINS 1104C-44
	48		Performance ISO / TR 14396	kW	64	64
	49		RPM	n/min	2400	2400
	50		Torque	Nm/ n	302/1400	302/1400
	51		cycles/ cylinders/ volume (cm3)		4/4/4400	4/4/4400
	52	Clutch	Type			
53	Shifting gears	Type		stepless	stepless	
54		no. of gears, forward/reverse				
55	Gearbox	Type		hydrostatic	hydrostatic	
Complements	56	Hydr. pressure	for attachments	bar	220	220
	57	Steering	Type		hydrostatic	hydrostatic
	58	Lighting	for road traffic Yes/No		Yes	Yes

*) without load, modification reserved without notice

h1 = h3 / 2 + 1125, h4 = h3 + 1125